

This tool is foreseen for the preparation of RF cables 1 1/4" and 1 5/8" before and during installation of the connectors.
It can be only used for the above mentioned function, please always refer to the instruction of the valid connector in addition!
These instructions are written for qualified and experienced personnel. Please study them carefully before starting any work. Any liability or responsibility for the results of improper or unsafe installation practices is disclaimed. Please respect valid environmental regulations for assembly and waste disposal. Always make sure to use appropriate personal protection!



Safety precaution: Sharp blade - Risk of injury => Protective gloves required



Main Parts of the Universal Trimming Tool

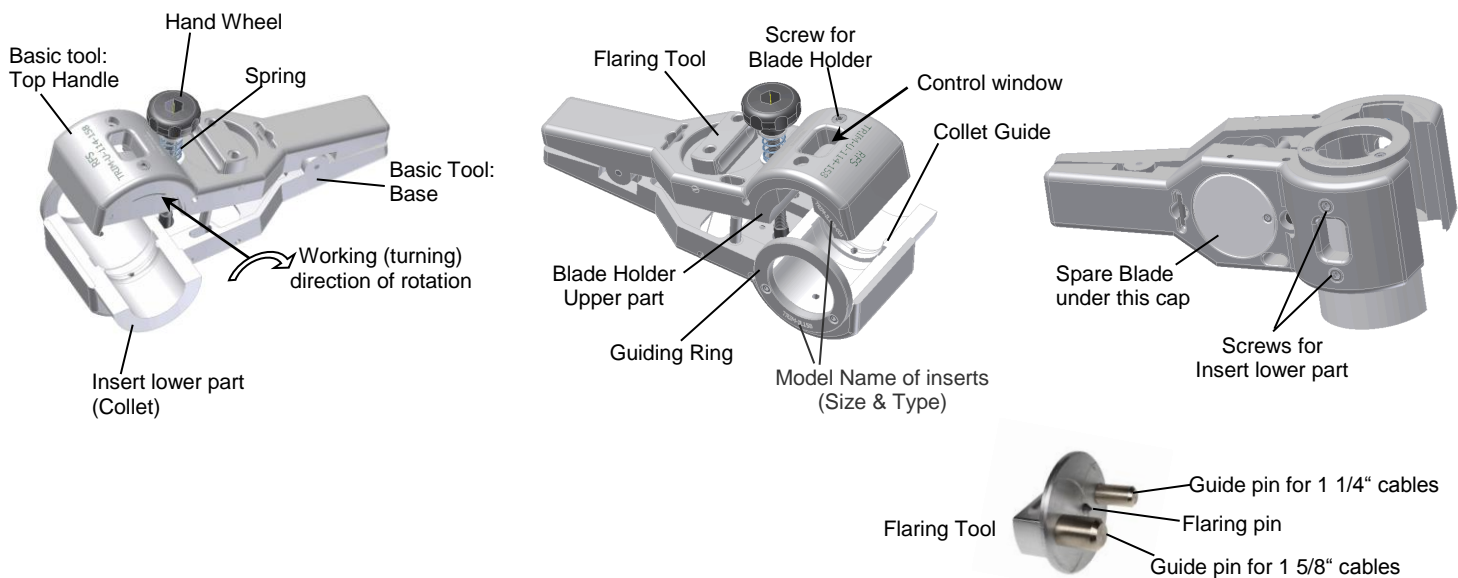

Preparation of the Tool - Change of the inserts:

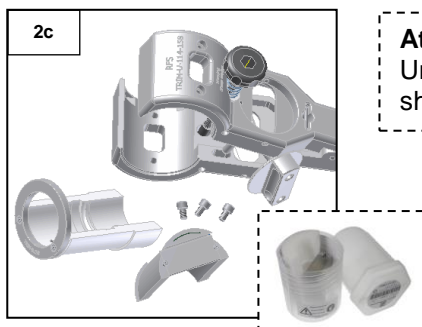
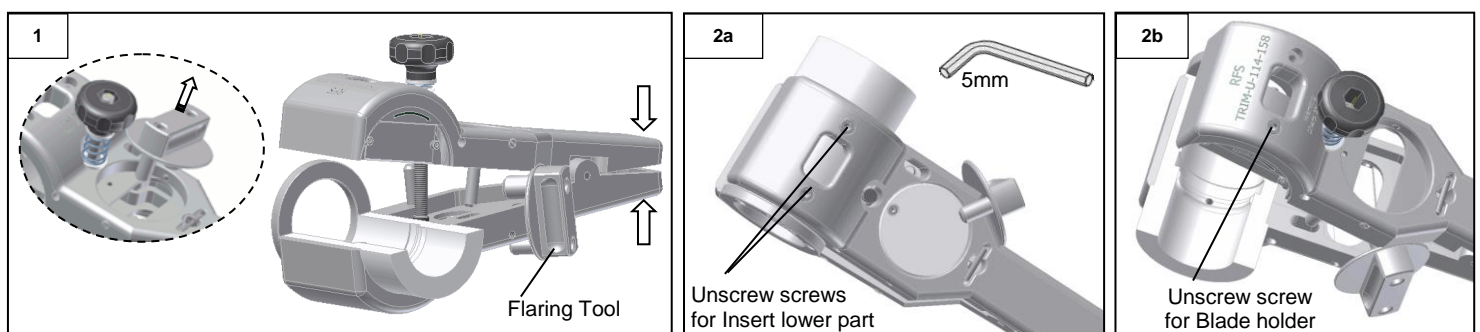

Attention:

Universal Trimming Tool to be handled and used with great care, blades are extremely sharp! It is recommended to use protective gloves.

1. Remove the Flaring Tool. Open the Universal Trimming Tool by pressing the base and the top handle together. Insert the flaring tool as a spacer as shown.
2. Unscrew the screws indicated in pictures 2a + 2b with hexagon socket 5mm and remove the inserts.
Place new inserts in the tool, make sure index hole in insert lower part and index pin are aligned, and carefully tighten the screws.
Because of safety reasons use the Plastic box for storage and transportation.

Blade Replacement:

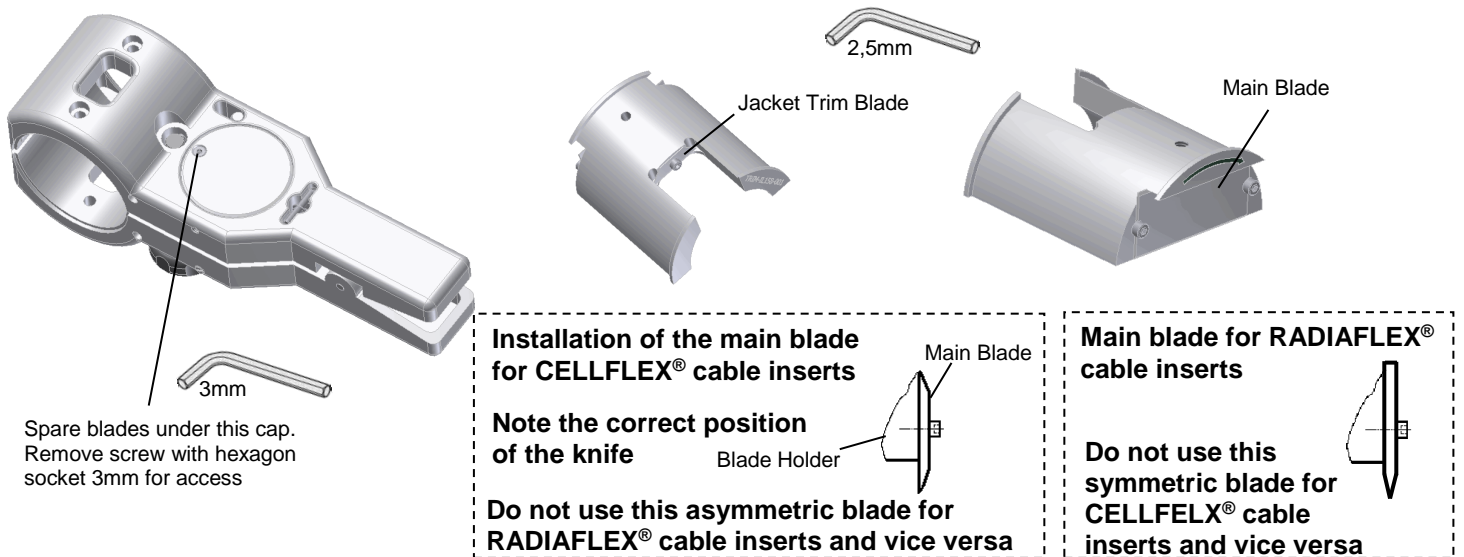

The blades are made of hardened steel. Therefore no commercially available cutting blades can be used as replacement. When the blades are worn-off replace with new blades.

- Remove Blade Holder from the tool as shown before.
- Unscrew and remove the screws with hexagon socket 2,5mm and change the blade. Observe that the cutting edge is being inserted symmetrically to the socket head screws. The bevelled edge points outwards as shown. Each Main Blade for CELLFLEX® cables and for RADIAFLEX® cables insert has a cutting edge on both sides, so that it can be used twice, by turning the blade by 180°.

Available Insert Kits and Spare Blades:



The Insert Kit contains a Collet (lower part) and a Blade Holder (upper part) with knives. It comes in a plastic box.

It is recommended to use this plastic box for safe storage and transportation.

Last Issue of the respective Installation Instruction for the connectors, tools and inserts are available on RFS website:

<http://www.rfsworld.com>

(enter Model Name of connector or tool, then follow the Link to the valid installation instructions on the bottom of the data sheet)

Cable Size	For the Installation of Connector types	Model Name of Insert Kit
CELLFLEX® cables LCFS/UCF 114-50	RAPID FIT 060/062	TRIM-IL114-001
	RAPID FIT 070/072	
	OMNI FIT Standard B32	TRIM-IL114-D01
	OMNI FIT Premium D01	TRIM-IL114-C02
CELLFLEX® cables LCF158-50	RAPID FIT 060/062	TRIM-IL158-001
	RAPID FIT 070/072	
	OMNI FIT Standard B32	TRIM-IL158-D01
	OMNI FIT Premium D01	TRIM-IL158-C02
RADIAFLEX® cables 1 1/4" sizes	All cable types with copper foil outer conductor except with jacket options JFCLA	
	For P01 and Standard Connectors	TRIM-IR-114-P01
	For P02 Connector series	TRIM-IR-114-P02
RADIAFLEX® cables 1 5/8" sizes	All cable types with copper foil outer conductor except with jacket options JFCLA	
	For P01 and Standard Connectors	TRIM-IR-158-P01
	For P02 Connector series	TRIM-IR-158-P02
Kit of Spare Blades (Main Blade)	All Inserts for CELLFLEX® cables	TRIM-B31
	All Inserts for RADIAFLEX® cables	TRIM-B34

Complete Universal tools (Body TRIM-U-114-158 + Insert Kit) are available under the Model Names:

TRIM-SET-L114-*** or TRIM-SET-L158-***

TRIM-SET-R114-*** or TRIM-SET-R158-***

(*** = CELLFLEX® Connector series)

(*** = RADIAFLEX® Connector series)

General Instruction of use for CELLFLEX® cables

-- Always refer to the respective connector installation instruction in addition! --

Attention:

Trimming tool to be handled and used with great care, blades are extremely sharp!
It is recommended to use protective gloves. Do not use great force.

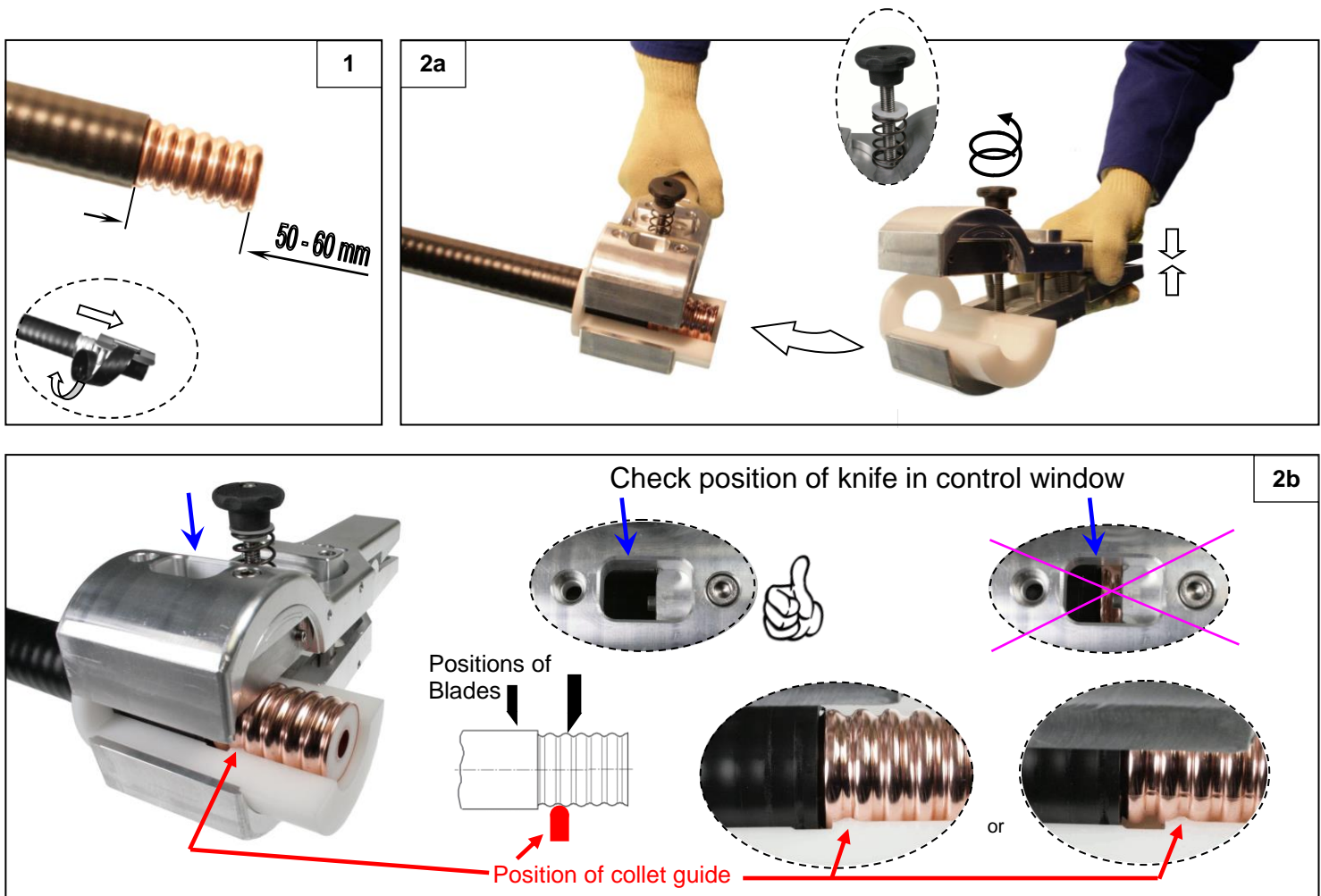

Keep the cable end downwards in order to prevent particles from entering during preparation.

1. Straighten the cleaned cable front part in a length of min. 200 mm (8"). Remove the cable jacket in a length of 50 – 60 mm (2,0 – 2,4 in), e.g. with a stripping tool (JSTRIP-114-2 for 1 1/4" or JSTRIP-158-2 for 1 5/8" CELLFLEX® cables). Do not damage the outer conductor!
2. Open the Universal Trimming Tool by pressing the base and the top handle together and insert the cable as shown. Position of the collet guide of the insert in a corrugation close to the trimmed cable jacket. The cable fits properly to the complete collet segment of the tool. The main blade is located on the crest (top) of the fourth – fifth corrugation and the jacket knife is in a non dismantled area (see control window).

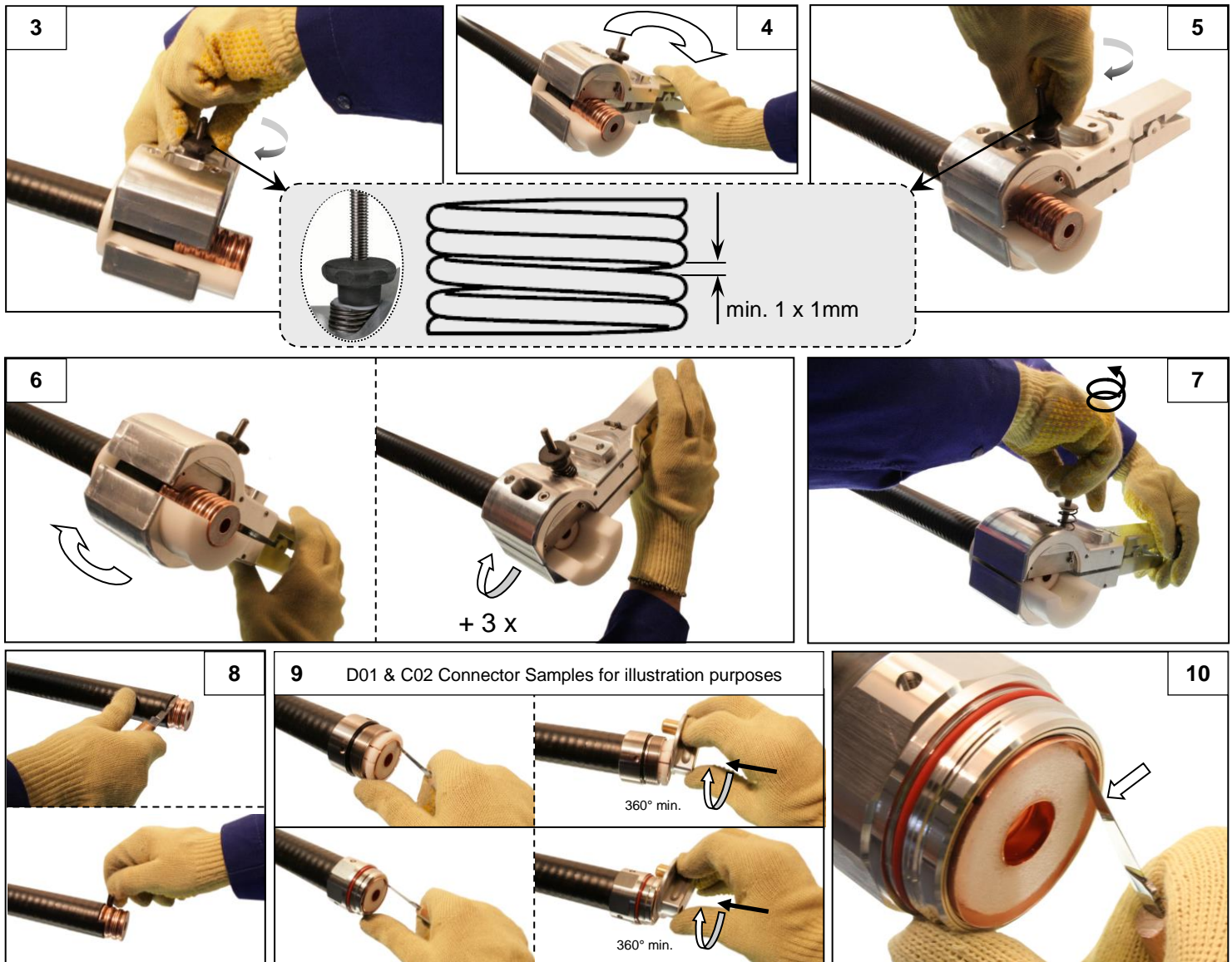

3. Keep the tool in the correct position; turn the hand wheel in order to tension the spring. Note: At least one gap should remain with a residual clearance of about 1mm (see sketch).
4. Rotate the Universal Trimming Tool around the cable in direction of the arrow shown on the tool until the outer conductor and the dielectric are been cut.
5. Re-adjust the hand wheel again as described in step 3.
6. Rotate the Tool again in the same direction as before. Once the cable is completely cut after several turns, continue turning the Tool min. 3 more times around the cable in order to make sure the jacket will be cut as well.
7. Unfasten the Tool by turning the hand wheel in opposite (counter clockwise) direction and remove the tool by pressing the handles together.
8. Deburr inner conductor. Carefully cut the jacket lengthwise with a knife; do not damage the outer conductor. Remove the jacket. Check trimming dimensions mentioned in the instruction of the connector. If the inner conductor should be deformed (from cutting), insert the cable guide pin of the flaring tool and carefully form it back to round.
9. Refer to the installation instruction of the connector to install the back part of the connector. Push a small part of dielectric to the centre in order to get a small free space for the flaring pin of the trimming tool. Insert cable guide pin of the Tool into the cable inner conductor, make sure that the flaring pin is located between outer conductor and foam/dielectric. Keep pushing the back-nut of the connector to the front, carefully turning the flaring tool with slight forward pressure to flare the outer conductor. Flare diameter has to be evenly round and concentric to the cable axis.
10. The flared area (cone) has to be free of any dielectric material, if necessary bend the dielectric back to the centre. Clean the prepared cable end, very carefully remove any particles. Continue installing the connector referring to the installation instruction of the connector.

General Instruction of use for RADIAFLEX® cables

-- Always refer to the respective connector installation instruction in addition! --

Attention:

Trimming tool to be handled and used with great care, blades are extremely sharp!
It is recommended to use protective gloves. Do not use great force.

Safety precaution: Sharp blade => Protective gloves required !

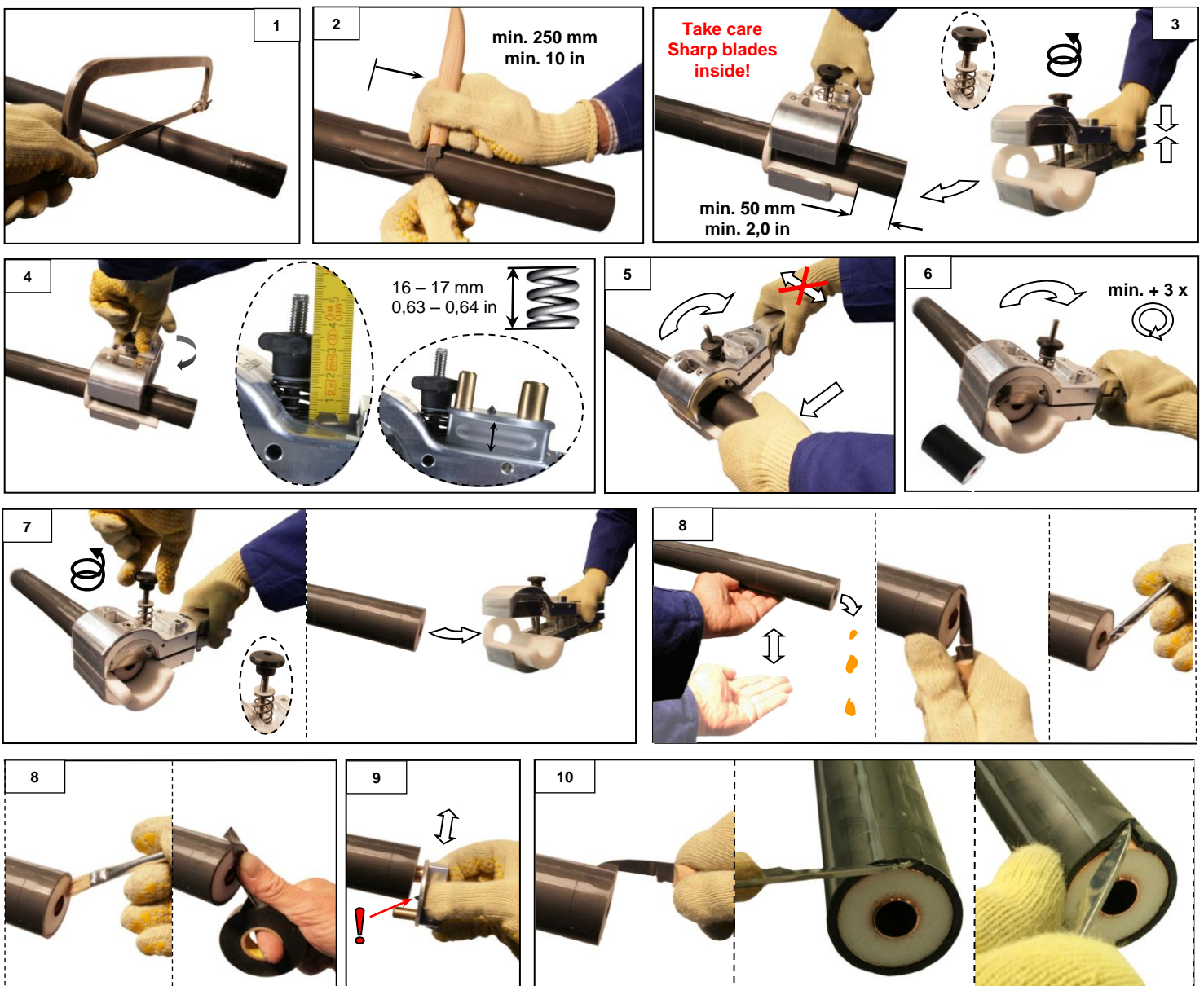

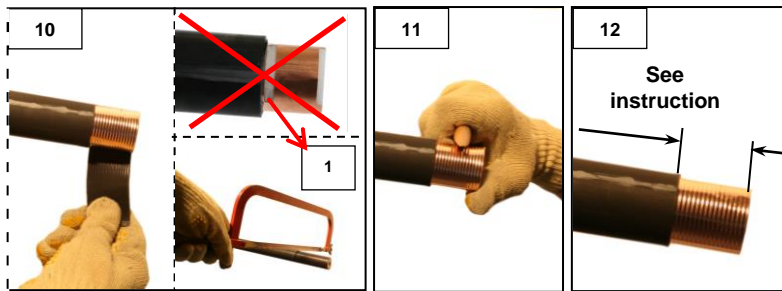

Keep the cable end downwards in order to prevent particles from entering during preparation.
 For optimum PIM performance we recommend to install the connector at a location where the outer conductor does not show slots in the dismantled area.

1. Straighten the cleaned cable end in a length of min. 500 mm (20 in). Cut of the end section if not straight able.
2. Slide with a knife atop the cable jacket in order to remove the two guides in a length of min. 250 mm (10 in).
3. Open the Universal Trimming Tool by pressing the base and the top handle together and insert the cable as shown. At least 50 mm (2,0 in) ahead of the cable end should protrude from the tool.
4. Keep the tool in this position and turn the hand wheel in order to tension the spring. Turn the hand wheel until the shown distance (Length of the spring) of 16 – 17 mm (0,63 – 0,64 in) is set. As shown at the picture, for this adjustment the flaring tool of the preparation tool can be used for checking the distance.
5. Rotate the Universal Trimming Tool around the cable in direction of the arrow shown on the tool until the jacket, the outer conductor and a part of the dielectric have been cut. Maintain a straight line while turning the tool around the cable – do not shift the tool laterally.
 While continue turning hold the cable end in position to ensure that the cut cable end cannot move or bend in any direction.
6. Once the cable is completely cut after several turns, continue turning the tool min. 3 more times around the cable in order to make sure the jacket will be cut as well.
7. Unfasten the tool by turning the hand wheel in opposite (counter clockwise) direction and remove the tool by pressing the handles together.
8. Clean the cable end, remove any particles very carefully. Particles which are inside the inner conductor can be removed by knocking the cable carefully from the bottom side, as well by the use of a brush in order to clean the inner conductor completely. Also remove any particles from the dielectric very carefully e.g. using a knife and a brush. It is not recommended to use steel or similar hard brushes, because these can deeply press particles inside the dielectric. Adhesive tape can be used additionally to remove the finest particles.
9. If the inner conductor has been deformed (from cutting), insert the cable guide pin of the flaring tool and forme it carefully back into round shape. Take care; do not insert the complete guide pin in order to avoid damaging the already prepared cable end with the flaring pin of the flaring tool (the flaring pin is need only for a later step).
10. Carefully cut the cable jacket lengthwise with a knife, do not cut the jacket completely – cutting a little more than half of the sheath thickness is sufficient. Do not damage the copper foil outer conductor!
 Stick a knife into the front part of the jacket - not between jacket and copper foil - and lift the jacket. Remove the jacket through tear, plies can be used carefully. Do not lift the copper foil; make sure that the overlapping foil is closed together.
 For optimum PIM performance we recommend to repeat the cable cutting if the outer conductor shows slots in the dismantled area. Repeat the cable cutting until there are no slots in the contact area of the connector.
11. If the outer conductor foil is slightly deformed, then smooth the foil e.g. with the wooden knife handle.
 Check the trimming dimension of the jacket.

Continue installing the connector referring to the installation instruction of the connector.